()

()			()		
()		()			
()					
()			()		
()					

()

()

()

()

()
)

(

()
(

)

()

	()		()			

				()		

				()		

()



(

)

()

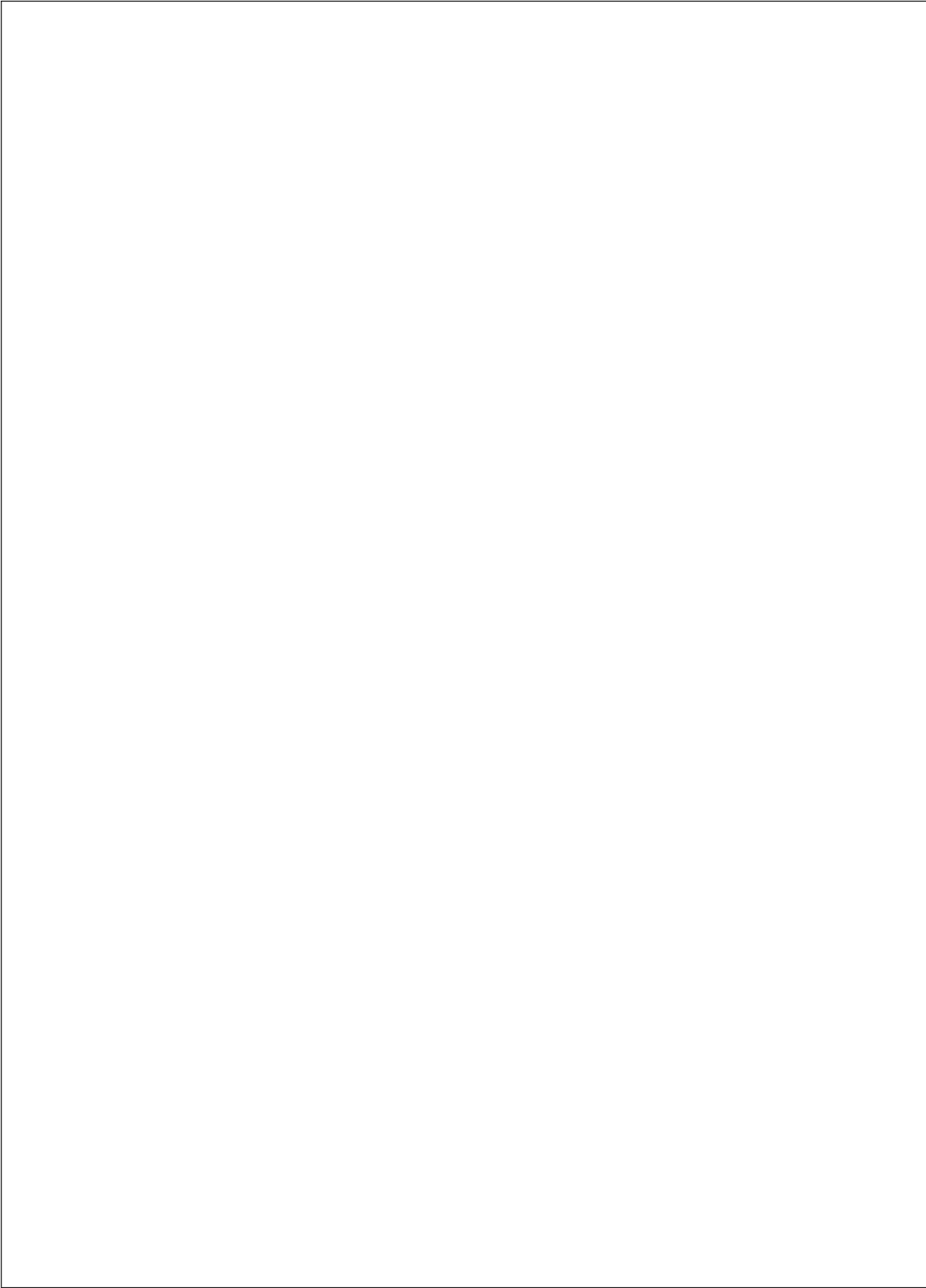



()

()

()

()

	()	()	

	()	()	()	()	
()					
			()	()	

()

_____ ()						
_____ ()						
_____ ()						

--	--

()

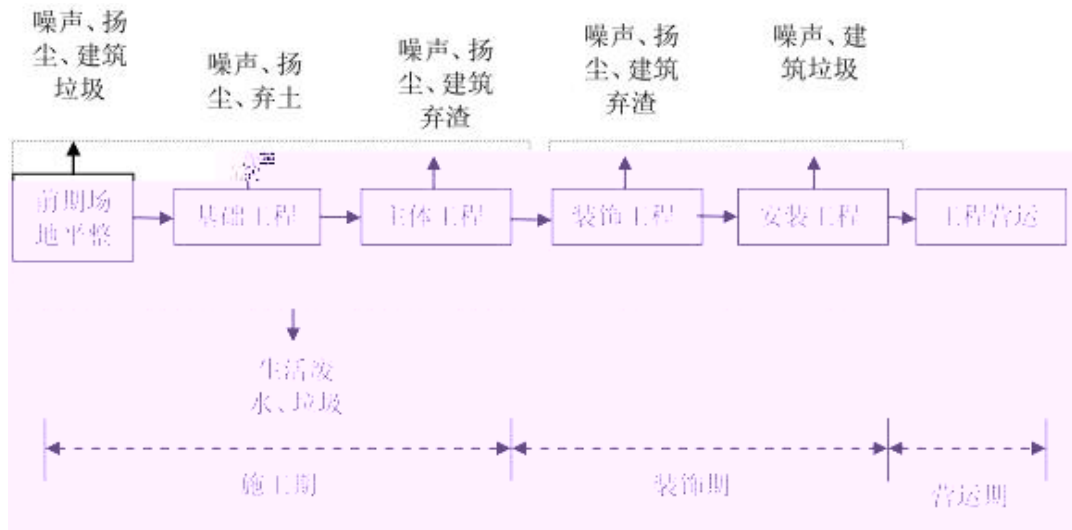

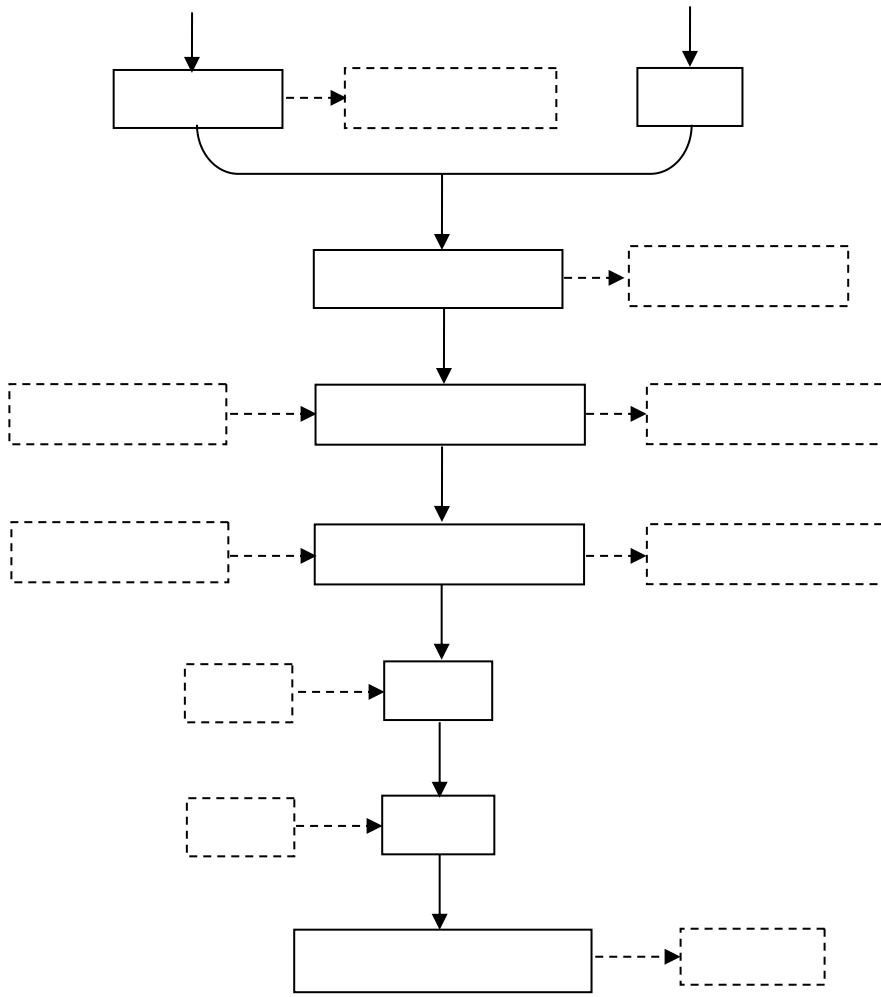

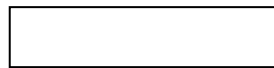
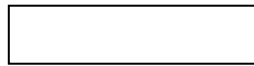

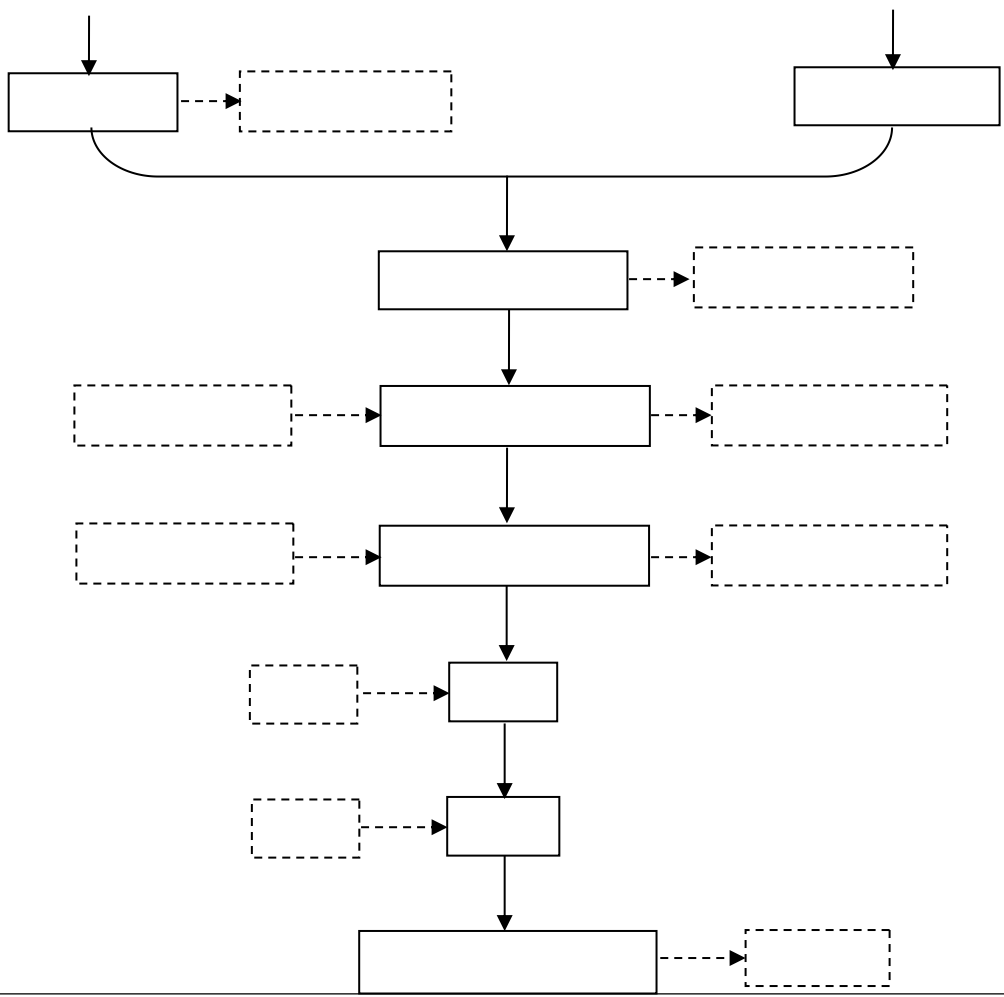

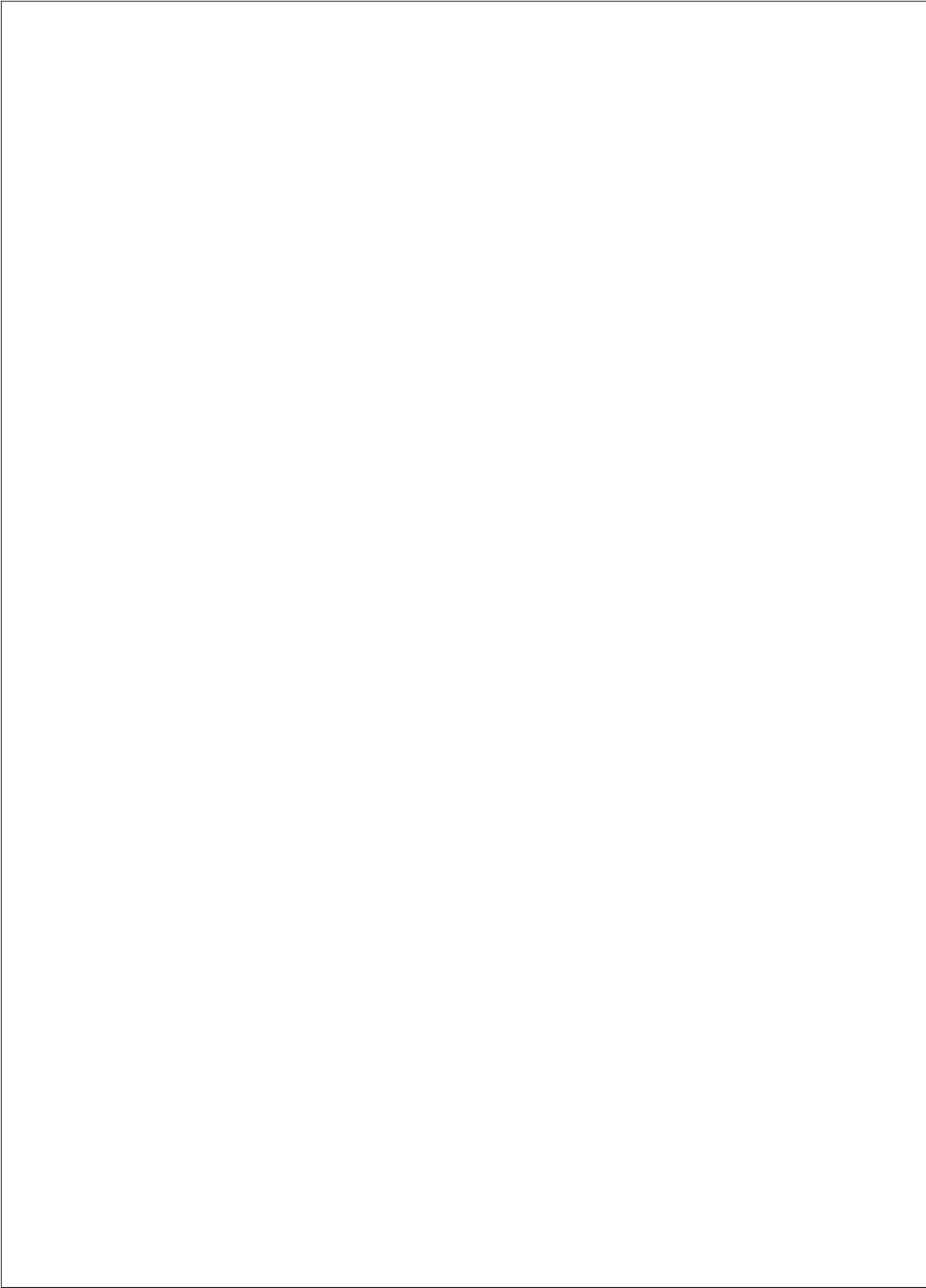

()

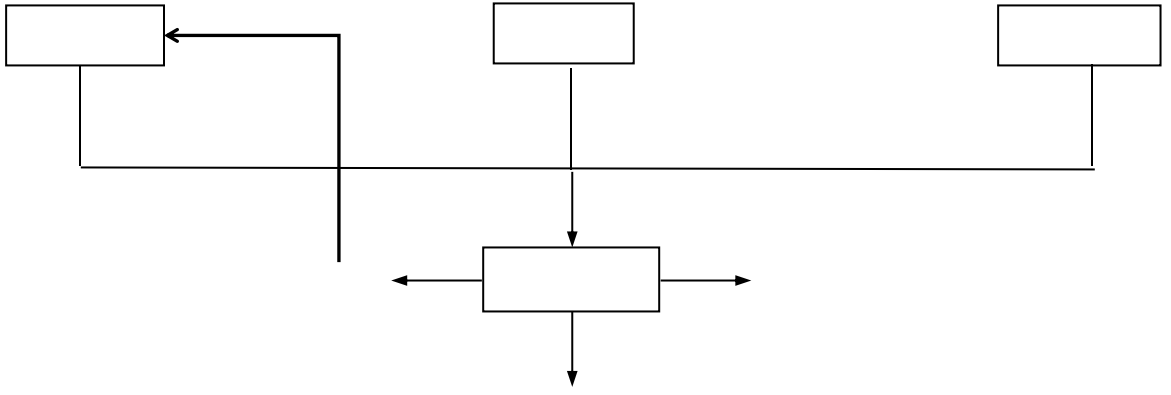

()

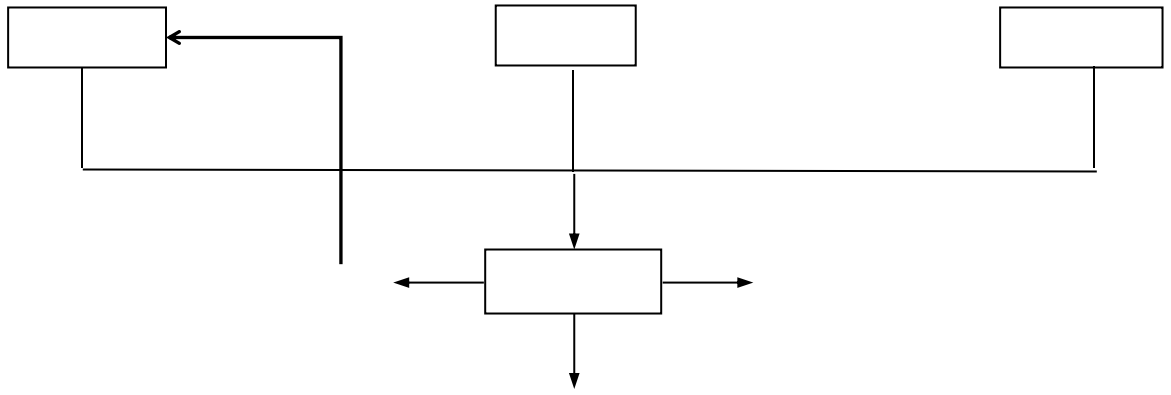

()

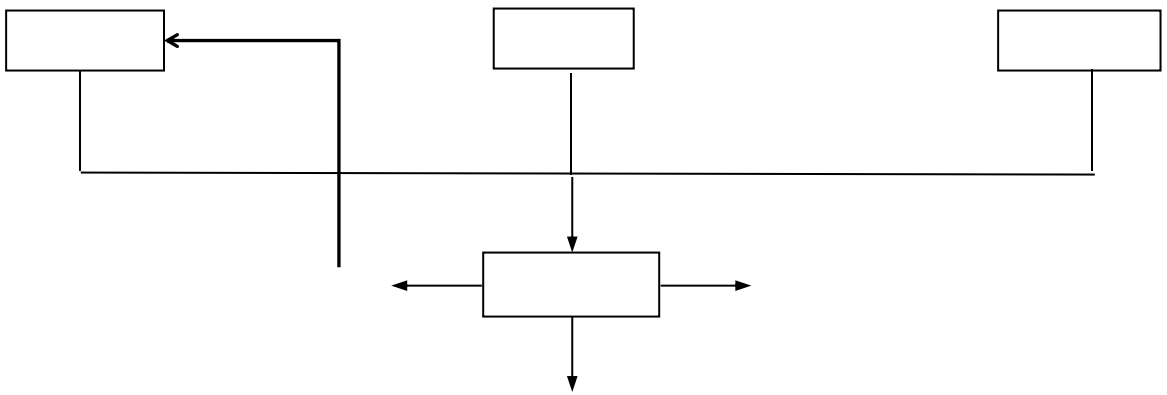

()

			()	()	()	()	()						

()

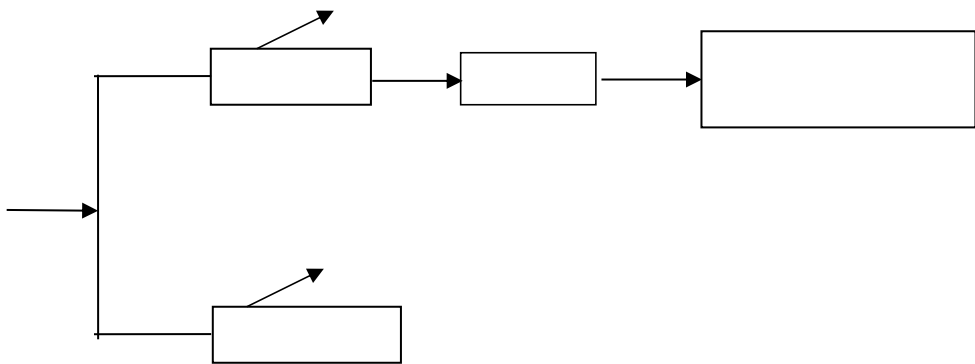

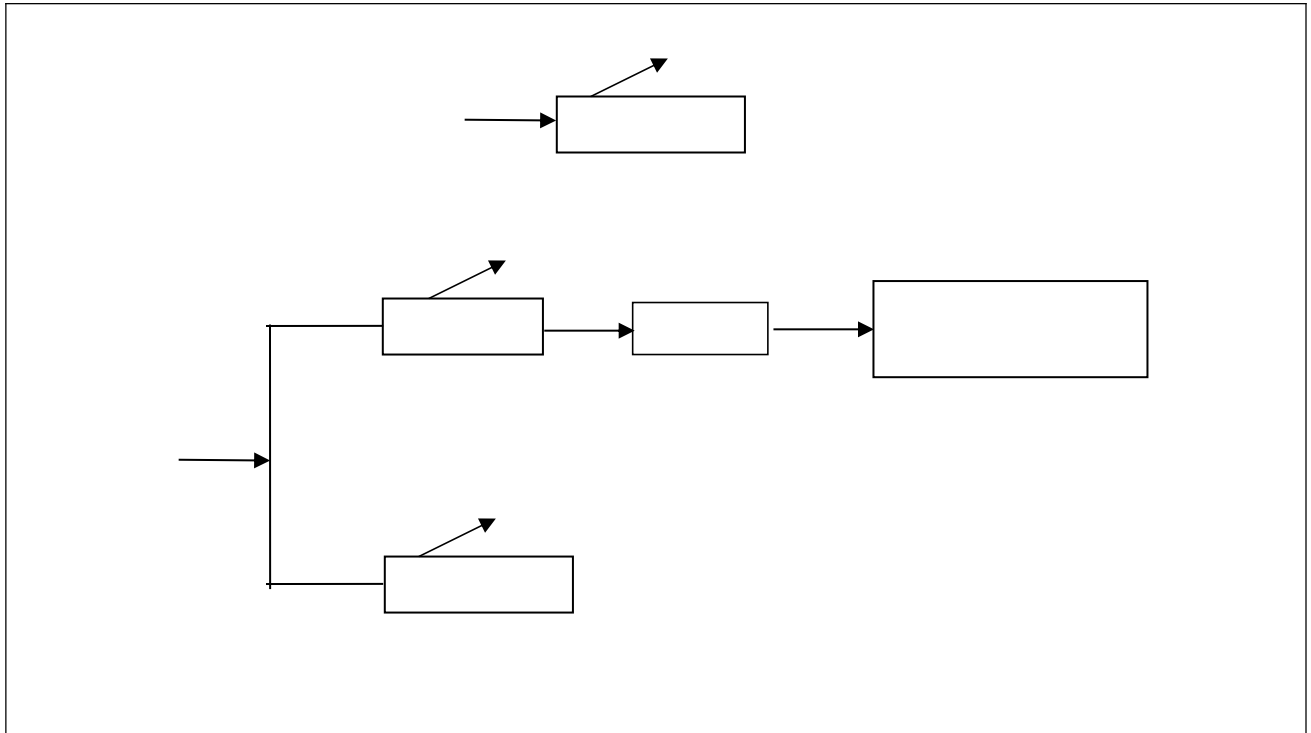

	()		()			()		
			()	()		()	()	

	()	()			()		()

--	--	--	--	--	--	--	--

--

Blank space for notes or a title.

Blank space for notes.

Blank space for notes.

										()			

	()							
	()	()	()		()	()		
	()							





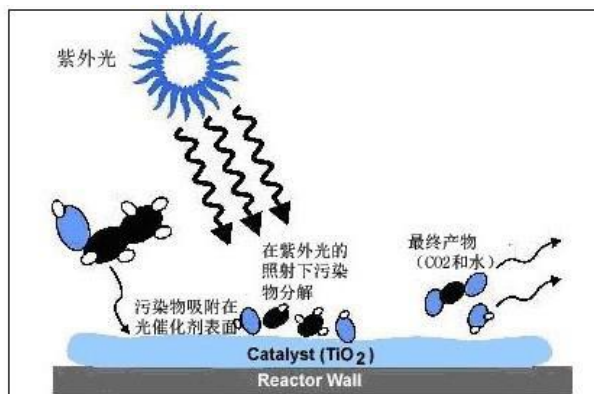
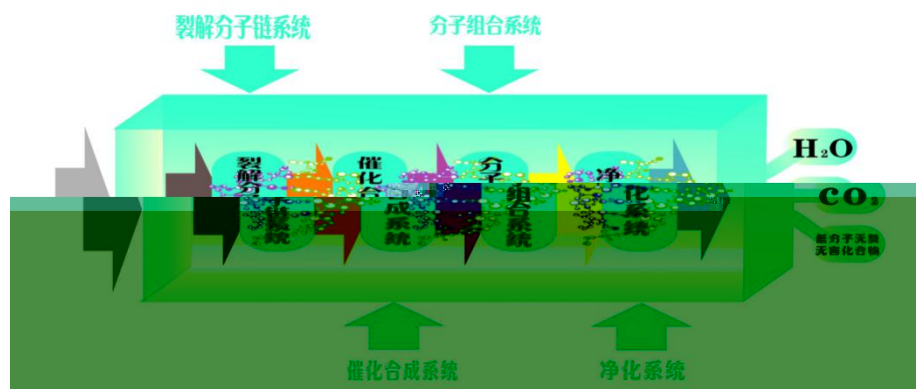

净化处理图：



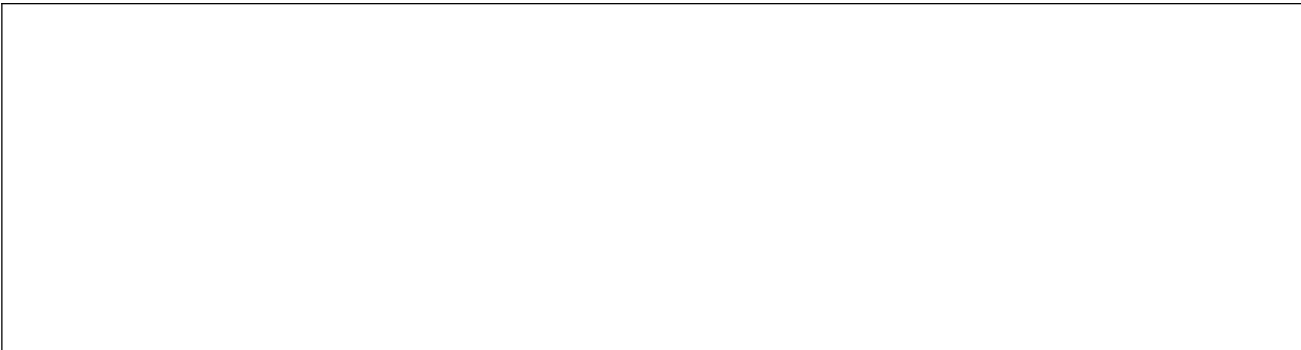

		()	()	()	()	



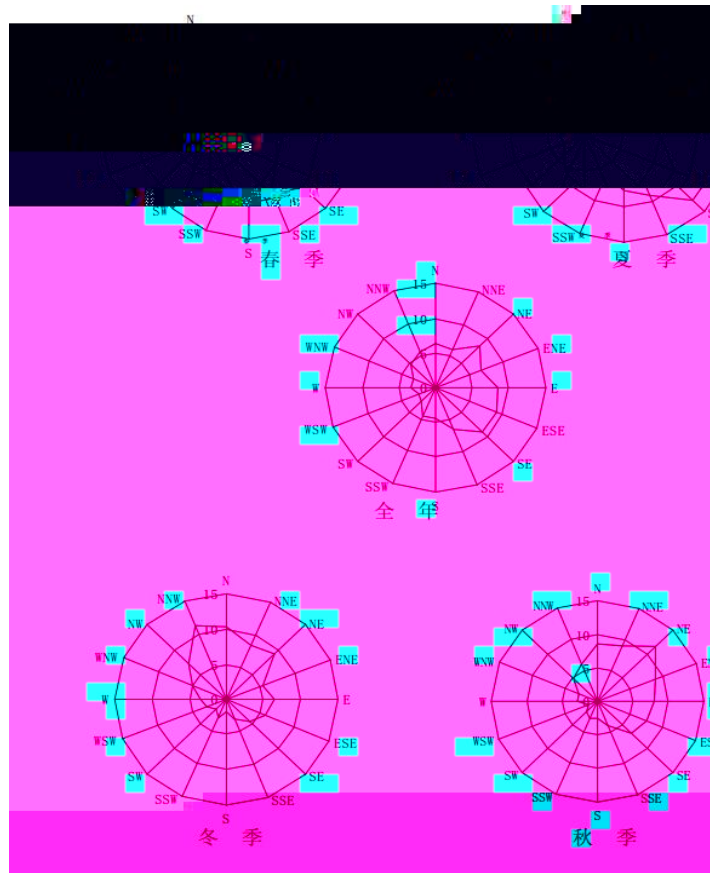

(%)

	% %

()

() (%) () (%) () (%) () (%)

%

() ()

()

$$L = \begin{bmatrix} L \\ -\sum_{=} L_A \end{bmatrix}$$

$$L = \begin{bmatrix} L + L \end{bmatrix}$$

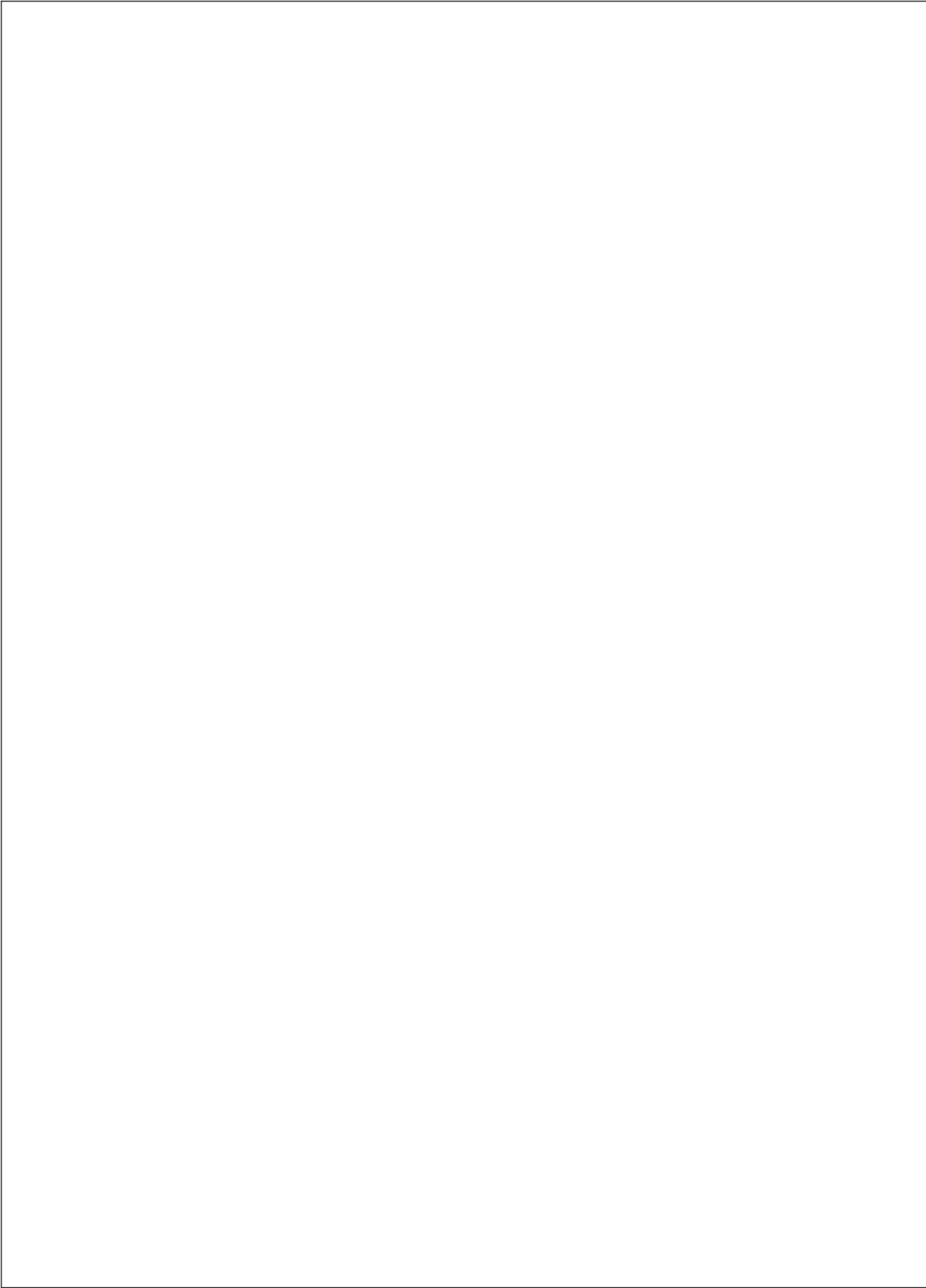



								()	

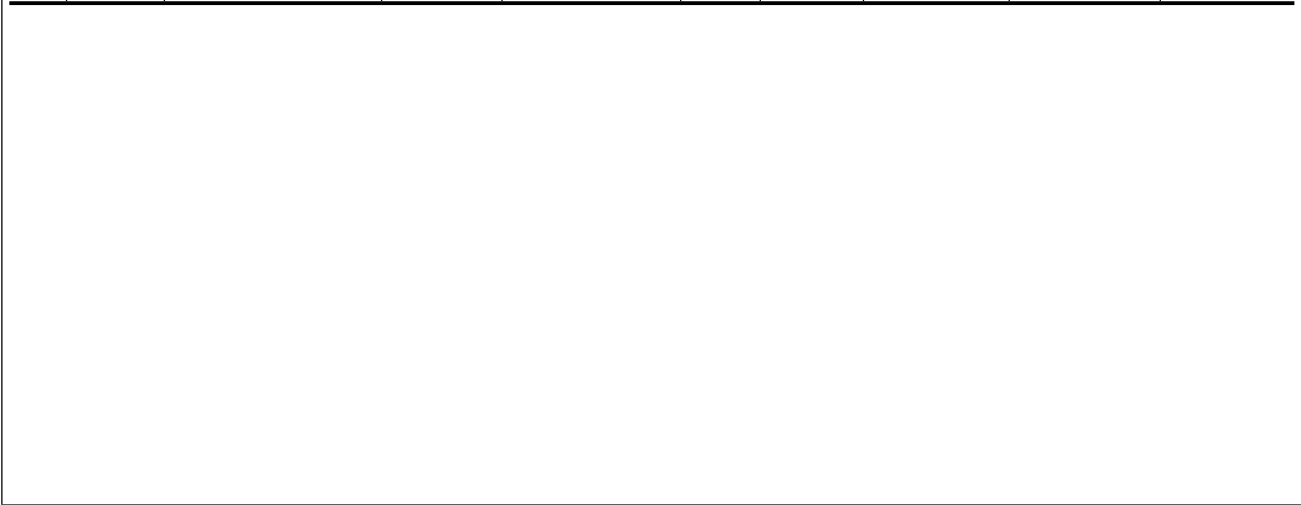

()

()

()

()

()

()

()

()	
()	

